

S-195.NGT.M4

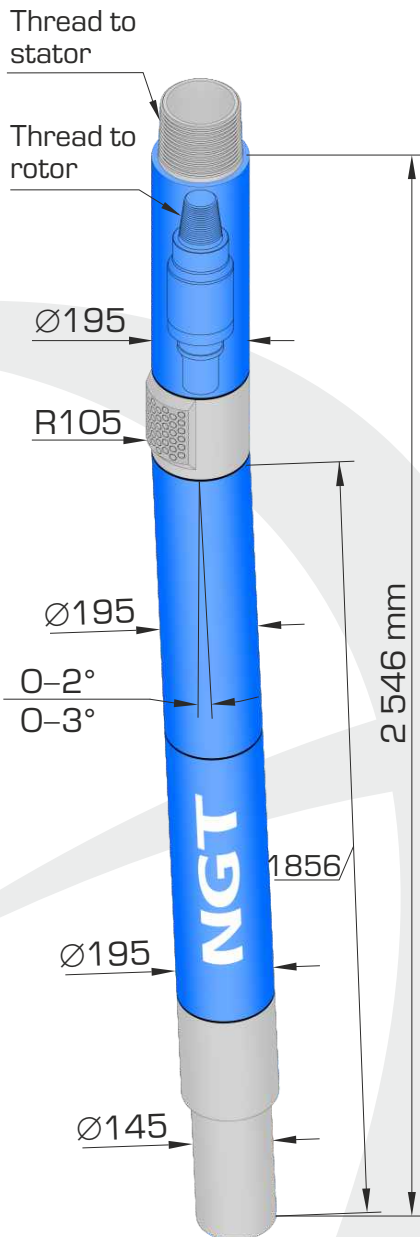

Bearing section S-195.NGT.M4 is a new short bearing section featuring enhanced operation life. The bearing section is used in PDM power sections of 195 mm diameter and for drilling oil and gas wells with 215.9 – 269.9 mm rock and PDC bits.

Axial bearing of bearing section is a multi-row thrust ball bearing with toroidal raceways, radial bearings of bearing section are steel sleeves, having the friction surfaces reinforced with hard-alloy plates.

The bearing section is furnished with drive shaft with two joints to connect to the power section rotor. The bearing section design has adjustable bent sub. The adjustment range is from 0° up to 2° or from 0° up to 3°.

Meeting customers' requirements, the bearing section can be produced with the connecting threads for specific power section.

Top sub (safety sub) and replaceable centralizer are available with the bearing section to connect the power section to drill pipes:

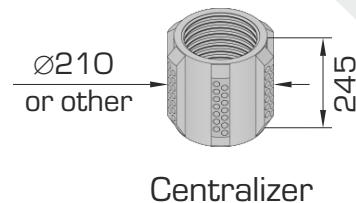

Technical specifications

Housing OD, mm	195
Bearing section length, mm	2 546
Bearing section length to curvature plane, mm	1 856
Range of angle adjuster change, degree	0-2 или 0-3
Connecting thread to bit	4 1/2 Reg
Torque transmitted, max. kN*m	27,0
Tolerance of axial loading, kN	250
Overhaul period, hour	250